

CONSTRUCTION

MATERIAL - The Series 8325 window is a 3-1/4" deep frame depth with a nominal wall thickness of 0.125 inch. All material is extruded from 6063-T6 alloy.

THERMAL BREAK - All framing members of the window system are thermally broken. Winco uses polyamide struts for all frame and vent extrusion profiles.

WEATHER-STRIP - All operating ventilators have a double Santoprene®, non-shrinking dual durometer, thermoplastic rubber weather-stripping around the perimeter. One interior and one exterior.

FABRICATION - The main frame corners are coped and mechanically joined using two stainless steel spline screws per corner (fig 1). The vent is a hollow tube shaped extrusion for superior strength and rigidity. Vent corners are fully mitered and mechanically joined using two stainless steel spline screws per corner, aligning the members to form a hairline joint (fig 2). All frame joints are back sealed with small joint seam sealer providing a water tight joinery.

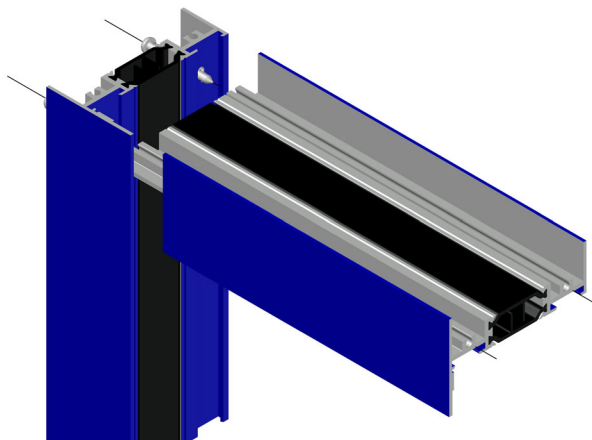

(fig 1) Main Frame Construction

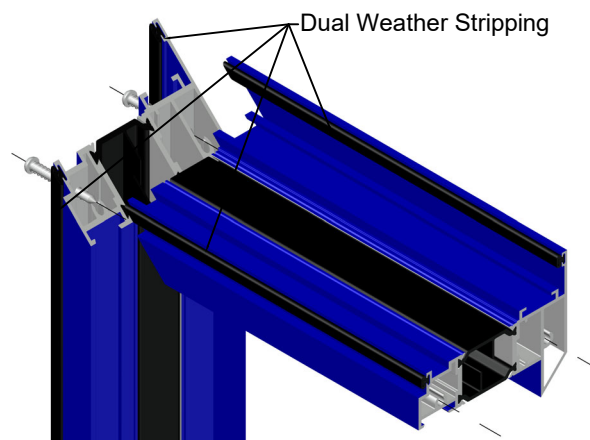

(fig 2) Vent Construction